



Acme Sanitary Ware Co. Ltd.

1/F, Acme Building, 22-28 Nanking Street, Kowloon, Hong Kong

Tel: 2388 7171 Fax: 2710 8012

Email: acme@acmesanitary.com.hk

Website: www.acmesanitary.com.hk

Since 1949

PROJECT		REF		REV	ITEM CODE	
LOCATION		DATE			PAGE	

SANITARY WARE SPECIFICATION SHEET

Item Descriptions	Koala Kare (USA) Horizontal wall mounted polyethylene baby changing station with stainless steel finish veneer	<p>Illustration/ Drawing </p> <p>Colors</p> <p>Grey 01 White Granite 05</p>
Dimensions	Refer to drawing	
Model	KB200-01SS Grey KB200-05SS White Granite	
Material	Polyethylene	
Manufacturer	Koala Kare (USA)	
Supplier	Acme Sanitary Ware Co. Ltd Mr. Eric Wong/ Mr. Don Yuen	
Contact Tel/Fax	(852) 2388-7171 / (852) 2710-8012	
E-mail	acme@acmesanitary.com.hk	
Website	www.acmesanitary.com.hk	

MATERIALS:
 FDA approved injection-molded polypropylene with Microban® antimicrobial additive embedded into the bed surface. Type 304 brushed stainless steel finish veneer. Reinforced steel-on-steel hinge mechanism and metal mounting chassis with mounting hardware included. Labelled usage instructions and safety messages in four languages. Optional Braille label available. Contoured changing surface area is 450 sq. in (2903 sq. cm) and comes complete with nylon safety strap and bag hooks. Dual cavity liner dispenser holds approximately 50 KB150-99 bed liners.

This Baby Changing Station has been tested to support **200 lbs** with minimal deflection.

OPERATION:

Concealed pneumatic cylinder and metal mounting chassis provides controlled, slow opening and closing of bed. Polypropylene is easy to clean and resists odors and bacterial growth. Complies with ASTM static load performance requirements when properly installed.

Warning: To ensure that the unit supports the intended loads, baby changing stations must be properly installed according to the manufacturer's instructions.

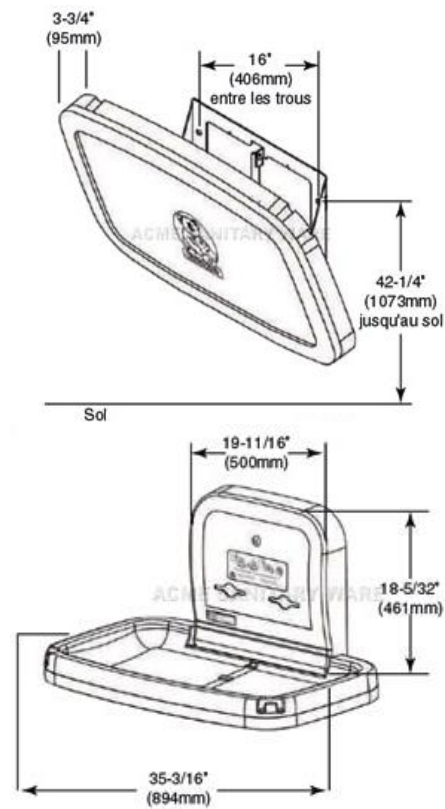
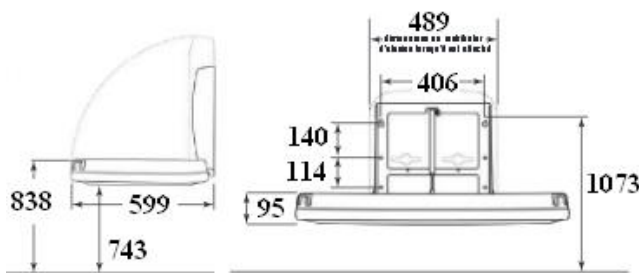

Note:

* All information of the above is for the reference only. No prior notice is made if any changes.

Source: Bobrick Washroom Equipment Inc.